

# Your property is now protected from sewage backups by a Clean Check® extendable backwater valve.

With appropriate maintenance, this valve will protect your property from sewer backups due to system overloads, blockages and flooding. It is your responsibility to

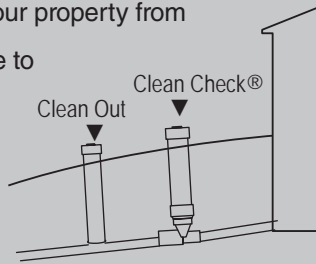

have this valve checked periodically to ensure that it is operating properly. Under normal installation and use, a three month inspection interval is recommended. It is also recommended that a licensed plumber perform these inspections.



#### Flapper removal:

With a flathead screwdriver, push down through the lower collar mount to the bottom clip edge of the flapper insert. Pull old flapper straight back and out.



#### Flapper replacement:

Snap in the replacement flapper by pushing it straight into the lower collar mount.

#### Replacement flapper:

Two sizes of replacement flappers are available from your local plumbing contractor or wholesale supplier. Check for the correct size for your Clean Check.

← 7¼ →



For Clean Check fitted with 6" adaptor/plug, replace with flapper **Part No. 96980**

← 9¼ →



For Clean Check fitted with 8" adaptor/plug, replace with flapper **Part No. 96982**



## Extendable Backwater Valve Maintenance Guide



2601 Spenwick Drive - Houston, TX 77055  
800-231-3345 www.rectorseal.com



# Maintenance Procedure

NOTE: Harmful bacteria are present in sewer lines. We recommend that you contact your local health district for proper sanitary precautions.



The following steps will guide your plumber through a proper inspection of your Clean Check® Extendable Backwater Valve.

- 1 Locate the Clean Check® cover. It has been placed outside your building, between the sewer lateral clean out and the building.
- 2 Remove the threaded cover plug by unscrewing it to expose the upper collar of the inner riser assembly.
- 3 Loosen, but do not remove, the stainless steel thumbscrew located inside the upper collar.
- 4 Note the locations of the thumbscrew and opposing notch. There are two notches: one in the upper collar and one in outer riser pipe (See Fig 3). This will be necessary for correct repositioning of the inner riser pipe during re-installation.



(Fig 1)

- 5 Using the finger hole provided opposite the thumbscrew of the upper collar, extract the entire inner riser assembly from the outer riser pipe and place it on the ground.
- 6 Clean debris from the flapper and inner riser assembly, as well as the in ground valve body.
- 7 Inspect the flapper for deterioration or damage caused by the harsh environment in which it operates. If deterioration is present, replace the flapper. (See back for replacement instructions and flapper part number)

For additional availability, contact: RectorSeal® Customer Service at 800-231-3345 for a local source.



(Fig 2)

- 8 The Clean Check® Extendable Backwater Valve is designed for easy re-installation. To properly re-seat the valve, slowly lower the inner riser assembly back into the outer riser pipe and rotate it until you feel the unit drop into place. The notch in the upper collar should now be lined up with the notch in the outer riser pipe. **Important:** Correct alignment of the notch in the upper collar and the notch in the outer riser pipe is necessary for correct repositioning of the inner riser assembly.

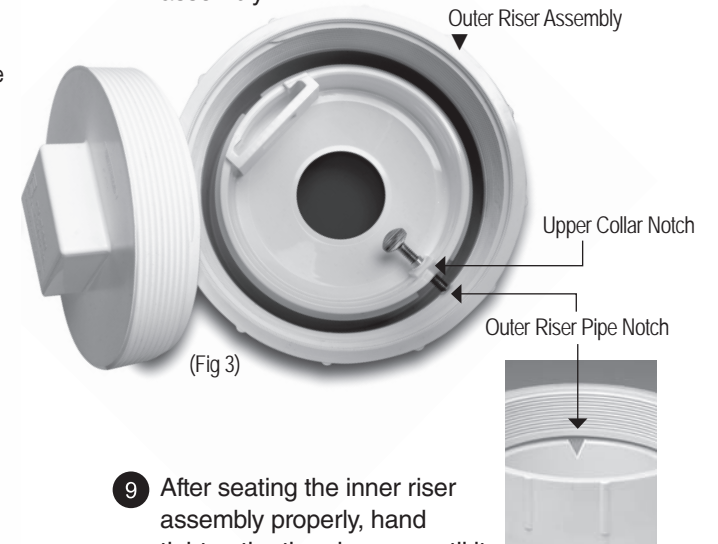

(Fig 3)

- 9 After seating the inner riser assembly properly, hand tighten the thumbscrew until it re-seats against the inside wall of the outer riser pipe. Be certain the thumbscrew is NOT resting on the top of the larger outer riser pipe. The flat side of the flapper should be resting, in the closed position, on the building side of the valve body.
- 10 Replace the threaded cover plug.