

VILLAGE OF OAK PARK

PROJECT NO: 2024 Ridgeland Ave Sewer Siphon Cleaning & Inspection

DATE ISSUED: 10/03/2024

!

REQUEST FOR PROPOSAL

INSTRUCTIONS AND SPECIFICATIONS FOR:

2024 Ridgeland Ave Sewer Siphon Cleaning & Inspection

The Village of Oak Park will receive proposals at the Public works Building Office of the Village Engineer, Monday through Friday, 8:30 a.m. to 4:00 p.m., at 201 South Blvd, Oak Park, Illinois 60302. **PROPOSALS CAN ALSO BE SENT ELECTRONICALLY TO msudkamp@oak-park.us.** Proposals will be accepted through **Thursday, October 24, 2024**, until 10:00 a.m. (local time). Proposals are anticipated to be presented to the Village of Oak Park Board for approval on November 12, 2024.

PROPOSALS MUST BE ENCLOSED IN SEALED ENVELOPES

The Board of Trustees reserves the right to accept or reject any and all proposals or to waive technicalities, or to accept any item of any proposal.

The documents constituting component parts of their contract, comprised of 32 pages, are the following:

- I. REQUEST FOR PROPOSAL
- II. PROPOSAL INSTRUCTIONS, TERMS AND CONDITIONS
- III. DETAILED SPECIFICATIONS
- IV. PROPOSAL FORM
- V. CONTRACTOR CERTIFICATIONS
- VI. TAX COMPLIANCE AFFIDAVIT
- VII. AFFIDAVIT OF COMPLIANCE
- VIII. E.E.O. REPORT
- IX. NO PROPOSAL EXPLANATION
- X. REFERENCES

Do not detach any portion of their document. Upon formal award to the successful vendor, a Contract will be issued to complete their contract.

II

PROPOSAL INSTRUCTIONS, TERMS AND CONDITIONS

Taxes Not Applicable:

The Village of Oak Park as a municipality pays neither Federal Excise Tax nor Illinois Retailers Occupational Tax, and therefore these taxes should be excluded from quotations.

Withdrawal of Proposals:

The vendor shall not withdraw or cancel their proposal after having been notified by the department that said proposal has been accepted by the Village of Oak Park.

Competency of Vendor:

No proposal will be accepted from or contract awarded to any person, firm or corporation that appears to be in default, or in any debt of any contract. The vendor, if requested, must present evidence to the Village of Oak Park of ability and possession on necessary facilities and financial resources to comply with the terms of the attached specifications and proposals.

Catalogs:

Each vendor shall submit catalogs, descriptive literature, and detailed drawings, where applicable, to fully illustrate and describe the material and/or work they proposes to furnish.

Conditions:

Vendors are advised to become familiar with all conditions, instructions and specifications governing their proposal. Once the award has been made, failure to have read all the conditions, instructions and specifications of their contract shall not be cause to alter the original contract or to request additional compensation.

Consideration of Proposals:

The department shall represent and act for the Village in all matters pertaining to their proposal and contract in conjunction therewith. The Village reserves the right to reject any or all proposals and to disregard any informality on the proposals when in its opinion, the best interest of the Village will be served by such action. No proposal will be accepted from or contract awarded to any person, firm or corporation that is in arrears of is in default to the Village of Oak Park upon any debt or contract, or that is a defaulter, as surety or otherwise, upon any obligation to said Village, or had failed to perform faithfully any previous contract with the Village.

The vendor, if requested, must present within forty-eight (48) hours evidence satisfactory to the Village of Oak Park of performance ability and possession of necessary facilities, pecuniary resources and adequate insurance to comply with the terms of these specifications and contract documents.

Subletting of Contract:

No contract awarded by the Village of Oak Park shall be assigned or any part subcontracted without the written consent of the Village of Oak Park. In no case shall such consent relieve the contractor from their obligations or change the terms of the contract.

Village Ordinances:

The contractor shall strictly comply with all ordinances of the Village of Oak Park and laws of the State of Illinois.

Inspection:

The Village shall have a right to inspect, by its authorized representative, any material, components or workmanship as herein specified. Materials, components or workmanship that have rejected by the Village of Oak Park as not in accordance with the terms of the contract specifications shall be replaced by the contractor at no cost to the Village.

Hold Harmless:

Vendor agrees to indemnify, save harmless and defend the Village of Oak Park, its agents, servants and employees, and each of them against and hold it and them harmless for any and all claims, actions, causes of action, demands, rights, damages, costs, loss of service expenses, compensation, court costs and attorneys' fees which the undersigned now has/have or which may hereafter accrue, directly or indirectly, for or on account of any and all known and unknown, foreseen and unforeseen, bodily and personal injuries to any person, or any death at any time resulting for such injury, or any damage to any property and the consequences thereof, which may arise or which may be alleged to have arisen out of or in connection with the work covered by their contract.

Termination of Contract:

The Village reserves the right to terminate the whole or any part of their contract, upon written notice to the Vendor, in the event that sufficient funds to complete the contract are not appropriated by the Village of Oak Park.

The Village further reserves the right to terminate the whole or any part of their contract, upon written notice to the Vendor, in case of default by the Vendor. Default is defined as failure of the Vendor to perform any of the provisions of their contract or failure to make sufficient progress to endanger performance of their contract in accordance with its terms.

In case of default and termination, the Village may procure, upon such terms and in such manner, as the Village of Oak Park may deem appropriate, supplies or services similar to those so terminated. The Vendor shall be liable for any excess costs for such similar supplies or services unless acceptable evidence is submitted to the Village of Oak Park that failure to perform the contract was due to causes beyond the control and without the fault or negligence of the Vendor.

Insurance:

Contractor shall at Contractor's expense secure and maintain in effect throughout the duration of this Contract, insurance of the following kinds and limits set forth in this Section. Contractor

shall furnish "Certificates of Insurance" to the Village before beginning work on the Project pursuant to this Contract. All insurance policies shall be written with insurance companies licensed to do business in the State of Illinois and having a rating of at least A according to the latest edition of the Best's Key Rating Guide; and shall include a provision preventing cancellation of the insurance policy unless thirty (30) days prior written notice is given to the Village. This provision shall also be stated on each Certificate of Insurance: "Should any of the above described policies be canceled before the expiration date, the issuing company shall mail thirty (30) days written notice to the certificate holder named to the left."

The limits of liability for the insurance required shall provide coverage for not less than the following amounts, or greater where required by law:

(A) Commercial General Liability:

- i. Coverage to include Broad Form Property Damage, Contractual and Personal Injury.
- ii. Limits:

General Aggregate	\$2,000,000.00
Each Occurrence	\$1,000,000.00
Personal Injury	\$1,000,000.00
- iii. Coverage for all claims arising out of the Contractor's operations or premises and anyone directly or indirectly employed by the Contractor.

(B) Workers' Compensation:

- i. Workers' compensation insurance shall be provided in accordance with the provisions of the laws of the State of Illinois, including occupational disease provisions, for all employees who perform the Work pursuant to this Contract, and if work is subcontracted pursuant to the provisions of this Contract, Contractor shall require each subcontractor similarly to provide workers' compensation insurance. In case employees engaged in hazardous work under this Contract are not protected under the Workers' Compensation Act, Contractor shall provide, and shall cause each subcontractor to provide, adequate and suitable insurance for the protection of employees not otherwise provided.

(C) Comprehensive Automobile Liability:

- i. Comprehensive Automobile Liability coverage shall include all owned, hired, non-owned vehicles, and/or trailers and other equipment required to be licensed, covering personal injury, bodily injury and property damage.
- ii. Limits:

Combined Single Limit	\$1,000,000.00
-----------------------	----------------

(D) Umbrella:

- i. Limits:
Each Occurrence/Aggregate \$5,000,000.00

(E) The Village, its officers, officials, employees, agents and volunteers shall be named as additional insureds on all insurance policies set forth herein except Workers' Compensation. The Contractor shall be responsible for the payment of any deductibles for said insurance policies. The coverage shall contain no special limitations on the scope of protection afforded to the Village, its officers, officials, employees, agents, and volunteers.

(F) Contractor understands and agrees that any insurance protection required by this Contract or otherwise provided by Contractor, shall in no way limit the responsibility to indemnify, keep and save harmless, and defend the Village, its officers, officials, employees, agents and volunteers as herein provided.

III

DETAILED SPECIFICATIONS FOR 2024 RIDGELAND AVE SEWER SIPHON CLEANING & INSPECTION

Description

This work shall consist of cleaning and inspecting by means of closed-circuit television (CCTV) the sewer siphon east of Ridgeland Ave under I-290 and providing reports of CCTV and chamber inspections.

General

The Contractor shall submit a work plan to be approved by the Engineer with the proposal which describes the methods and sequence of work, assumed number of hours for each sequence of work, number of working days for each operation, and description of equipment being used to perform each operation. The Contractor shall follow the maintenance procedure as shown on the included maintenance procedure drawing and as revised by this specification or the approved work plan submitted by the Contractor.

The Contractor shall obtain a hydrant water meter from the Village of Oak Park for a \$1500 deposit. All water used by the Contractor shall be metered. The Village of Oak Park will invoice the Contractor for water usage on this project. The Contractor shall invoice the Village for the actual cost of the invoice for the water usage from the Village of Oak Park, without increased costs or markups for administration. The Village will reimburse the Contractor for the actual cost of the water bill and refund the deposit on the hydrant meter upon successful completion of the project and returning of the water meter so long as all water used on the project was metered.

All CCTV inspections shall be performed in accordance with NASSCO's pipeline assessment certification program (PACP) standards.

Sewer chambers are confined spaces as defined by Federal and State regulations governing confined space entry and safety procedures in such areas. The Contractor shall be responsible for compliance with all OSHA, IDOL, State, and Federal standards and codes pertaining to confined space entry in performance of work under this contract. The Village of Oak Park shall supply the Contractor with sewer atlases prior to televising operations. Sewer atlases will identify manhole numbers which shall be used for all televising inspections.

Equipment

Cleaning Equipment

High-Velocity Jet Equipment shall be used on this project. All high-velocity sewer cleaning equipment shall be constructed for ease and safety of operation. The equipment shall have a selection of two or more high-velocity nozzles. The nozzles shall be capable of producing a

scouring action from 15 to 45 degrees in all size lines designated to be cleaned. The equipment shall carry its own water tank.

TV Camera

The television camera used for the inspection shall be one specifically designed and constructed for such inspection. The camera shall be capable of radial view for inspection of the top, bottom, and sides of pipe and for looking up lateral connections. The camera shall be mounted on adjustable skids, or self-propelled, to keep it in the center of the pipe. Lighting of the camera shall be supplied by a lamp on the camera, capable of being dimmed or brightened remotely from the control panel. The lighting system shall be capable of lighting the entire periphery of the pipe. The camera shall be operative in 100% humidity conditions and shall have a minimum of 650 lines of resolution and tested at 400 psi. The view seen by the televising camera shall be transmitted to a monitor. The camera, television monitor, and other components of the video system shall be capable of producing a picture quality satisfactory to the Engineer; and if unsatisfactory, the equipment shall be removed and no payment will be made for an unsatisfactory inspection.

Construction Requirements

Traffic Control and Protection

The Contractor shall furnish all necessary signs, markings, traffic control devices, and flagmen as may be required to maintain a safe work zone. The Contractor shall follow applicable IDOT and Manual of Uniform Traffic Control Devices for Streets and Highways standards, including, but not limited to, IDOT Standards 701301 and BLR18-5. The Contractor shall install advanced warning signage according to IDOT District 1 Standard TC-10.

The Contractor shall close the east-west alley adjacent to the north siphon chamber during working hours. The Contractor shall maintain eastbound traffic on Garfield during working hours. The Contractor shall restrict westbound traffic on Garfield to "Local Traffic Only" during working hours. The Contractor shall submit a traffic control plan for approval.

The Contractor shall install "No Parking" signs on Garfield from Ridgeland to Cuyler. "No Parking" signs shall have dates and times of restrictions clearly written. The Village shall provide a pdf file of the No Parking sign to be used. The Contractor shall furnish and install "No Parking" signs. Signs shall be taped or tied to trees and streetlights. Stapling of signs to trees is prohibited.

Basis of Payment

The work shall be paid at Lump Sum contract unit price for TRAFFIC CONTROL AND PROTECTION.

Upper Chamber Cleaning and Inspection

The Contractor shall clean with jetter-vacuum trucks and visually inspect the upper levels of each chamber and record the inspection with a digital video and still camera. The Contractor shall take notes and measurements regarding any conditions which indicate any structural defects of the chamber and include these notes in a report with corresponding still photos or the defect areas.

Inspection mpeg videos and reports shall be delivered on the same media (hard drive or flash drive) as the CCTV inspections. Mpeg video shall be the same format as for CCTV inspection.

The Engineer will be on site for all sewer chamber inspections to review video as it is being recorded. The Contractor shall make any measurements, visual inspections, or investigations as requested by the Engineer while inspecting the sewer chambers.

The Contractor shall inspect the condition and check for signs of damage of the existing stop planks in both chambers (upper and lower sections). The Contractor shall verify dimensions of planks. The Contractor shall submit a list of planks to be replaced to the Engineer for approval. The Contractor shall submit a material cost estimate for plank replacement and an estimate number of hours required to complete the work for approval. The work for inspection of stop planks and cost estimation for stop plank shall be included in the cost for UPPER SEWER CHAMBER CLEANING AND INSPECTION. The work for STOP PLANK REPLACEMENT shall be paid separately on a force account basis.

Basis of Payment

The work shall be paid at the contract unit price per hour for UPPER SEWER CHAMBER CLEANING AND INSPECTION. DEBRIS DISPOSAL shall be paid at the contract unit price per ton for DEBRIS DISPOSAL.

Perforated Drain Pipe Inspections:

The Contractor shall inspect the two 12-inch perforated under-drain pipes via CCTV inspection and perform light cleaning (up to two passes) only if required. The north section of perforated pipe is approximately 180 feet and the south section of drain pipe is approximately 207 feet (see included plan and profile sheet for layout). The attached photographs of the south chamber indicate the perforated pipe from this chamber is not clogged. The Contractor shall only clean the perforated pipe with low volume jetting if they are found blocked. The Contractor shall submit cleaning method and flow rates to be used to ensure no damage to drain pipe or surround utilities and pavements occurs during cleaning operations. The Contractor shall notify the Engineer if the perforated pipe from either chamber is completely blocked after light cleaning operations. The Engineer and the Contractor will determine how to proceed with any further cleaning operations for the perforated pipe and the remaining work under this contract. Additional cleaning of drain pipes shall be paid for on a force account basis.

The remaining siphon cleaning and inspection work under this contract is assumed to proceed with the drain pipes in working condition to drain the lower chambers. Alterations in the contract to allow for pumping of water from lower chambers to upper chambers to bypass the

perforated drain pipes shall be done on a force account basis according to Section 104 of the Illinois Department of Transportation Standard Specifications for Road and Bridge Construction adopted January 2022.

Basis of Payment

The work shall be paid at the contract unit price per foot for PERFORATED DRAIN PIPE INSPECTION.

Sewer Siphon Cleaning and Inspection

The Contractor shall follow the maintenance procedure for cleaning and inspecting the three sewer siphon pipes. The Contractor shall protect the 12-inch perforated drain pipes from debris during cleaning and inspection operations.

The Contractor shall use certified commercial divers during the removal of the flanges for the 30-inch and 54-inch sewers. The Contractor shall inspect flanges and bolts for damage. Replacement of flanges or bolts shall be on a force account basis for material.

The Contractor shall jet and clean the sewer pipes into the south chamber and vacuum debris from the south chamber.

The Contractor shall inspect each sewer pipe via CCTV following its cleaning. Acceptance of sewer line cleaning shall be made upon the successful completion of the television inspection and shall be to the satisfaction of the Engineer. If TV inspection shows the cleaning to be unsatisfactory, the Contractor shall be required to re-clean and re-inspect the sewer line until the cleaning is shown to be satisfactory. Television inspection shall be according to Television Inspection Requirements including in this specification below.

The Contractor shall reinstall the existing flanges and bolts.

The Contractor shall clean with jetter-vacuum trucks and visually inspect the lower levels of each chamber and record the inspection with a digital video and still camera following the cleaning and inspection of siphon pipe operations. Inspection and reports for the lower chambers shall follow the requirements of the UPPER CHAMBER CLEANING AND INSPECTION.

Basis of Payment

CCTV Inspection of sewer siphon pipes will be measured for payment in feet of sewer televised of the diameter specified for SEWER TELEVISION INSPECTION. FLANGE REMOVAL and all work requiring commercial divers shall be paid at the contract unit price per hour for FLANGE REMOVAL. Cleaning of sewer siphon pipes and lower chamber shall be paid at the contract unit price per hour for SEWER SIPHON CLEANING. DEBRIS DISPOSAL shall be paid at the contract unit price per ton for DEBRIS DISPOSAL. Inspection and reports of lower chamber shall be included in the cost for SEWER SIPHON CLEANING.

Television Inspection Requirements

The television camera shall be moved through the line in either direction at a uniform rate, stopping when necessary to insure proper documentation of the sewer's condition but in no case will the television camera be pulled at a speed greater than 30 feet per minute. Manual winches, power winches, TV cable, and powered rewinds (or other devices that do not obstruct the camera view or interfere with proper documentation of the sewer conditions) shall be used to move the camera through the sewer line. If, during the inspection operation the television camera will not pass through the entire sewer section, the Contractor shall re-setup their equipment in a manner so that the inspection can be performed from the opposite manhole. If, again, the camera fails to pass through the entire sewer section, the inspection shall be considered complete and no additional inspection work will be required. All costs for re-setup due to an obstruction in the sewer that will not allow the camera to pass shall be considered incidental.

Whenever non-remote powered and controlled winches are used to pull the television camera through the line, telephones, radios, or other suitable means of communication shall be setup between the two manholes of the section being inspected to insure good communications between the members of the crew.

The location meter, for accurately recording the location of the television camera with respect to the reference manhole, shall be a direct reading, above ground, friction clamp device or other suitable equipment. Marking on the cable, or the like, which would require interpolation for depth of manhole, will not be allowed. The meter shall be capable of reducing readings for reverse movement of the camera and shall be capable of being manually re-zeroed for each new setup.

The importance of accurate distance measurements is emphasized. Accuracy of the measurement meter shall be checked daily by use of a walking meter, roll-a-tape, or other suitable device. Footage measurements shall begin at the centerline of the upstream manhole and end at the centerline of the downstream manhole. Footage shall be shown on the video data view and recorded at all times.

All manholes at which entry is made into sewers to be inspected are to be assigned a discrete number corresponding to the manhole number shown on the sewer atlases provided by the Engineer. Manholes may not be assigned more than one number regardless of the number of sewer lines inspected which enters that manhole. Manhole numbers shall be spray painted in pink on the corresponding manhole lid. The Contractor shall clearly mark all manhole numbers on the atlas for manholes encountered which are not shown on the atlas. The Contractor shall identify these manholes using the upstream manhole ID with a lettered suffix (eg_A) for the new manhole ID. The Contractor shall provide the atlas to the Village of Oak Park upon completion of contract.

Documentation

Television Inspection Logs: The logs shall be computer printed and acceptable to the Owner. Printed location records shall be kept by the contractor and will clearly show the location, in

relation to adjacent manholes, of each infiltration point discovered by the television camera. An estimate of the flow rate of observed infiltration points shall be made and recorded. In addition, other points of significance such as locations of building sewer laterals, joints, unusual conditions, roots, storm sewer connections, collapsed sections, presence of scale and corrosion, and other discernible features will be recorded and one copy of such record shall be supplied to the Owner.

Television inspection logs shall include, but are not limited to, the following information:

1. Date, time, city, street, basin, sewer section, reference manhole number, name of operator, inspector, and weather conditions.
2. Pipe diameter, pipe material, section length, depth of pipe, length between joints, and corresponding videotape identification.
3. Location of each point of leakage.
4. Location of each service connection.
5. Location of any damaged sections, nature of damage, and location with respect to pipe axis.
6. Deflection in alignment of grade of pipe.

Recordings shall include the following information:

1. Visual (on screen in corner):
 - a. Report number.
 - b. Date of television inspection.
 - c. Sewer section and number.
 - d. Current distance along reach (tape counter footage).
2. Audio
 - a. Date and time of television inspection, operator name, name of overlying or adjacent street, and manhole numbers.
 - b. Verbal confirmation of sewer section and television direction in relation to direction of flow.
 - c. Verbal description of pipe size, type, and pipe joint length.
 - d. Verbal description and location of each service connection and pipe defect.

e. Type of weather during inspection.

The Contractor shall supply an MS Excel spreadsheet with street name, manhole numbers, date, length, structural and maintenance scores, and with hyperlinks to the individual sewer television segment videos and to the inspection reports in pdf format. The manhole numbers will be provided by the atlas information and Village's GIS. The Engineer shall provide the Contractor with the field name prior to work starting. The names of the files, folders, PDFs, etc. shall use the Unique IDs from the atlas information and Village's GIS.

The Contractor shall follow PACP defect codes and grades for both structural and maintenance observations and defects.

Television inspection data shall follow NASSCO's standard PACP database based on **MS Access**. Television inspection software shall be certified by PACP.

Television inspection videos shall be stored in the MP4 format. All inspection reports and videos shall be delivered on a portable hard drive or flash drive. Contractors which have previously supplied portable hard drives to the Village of Oak Park are required to combine the data from this contract with previously supplied inspection databases on existing or new portable hard drives depending on available storage space on hard drives. Hard drives with previous inspection data shall be obtained from the Village of Oak Park.

Final Restoration

The Contractor shall protect all curbs, sidewalks, and landscaped areas from damage during work. The Contractor shall replace in-kind any curb, sidewalks, and landscaped areas damaged during the sewer siphon cleaning and inspection work. The cost for replacement of any areas damaged during work shall be incidental to the contract.

Completion Date and Failure to Complete Work on Time

Ridgeland Avenue Sewer Siphon Cleaning and Inspection shall be completed and all reports delivered to the Engineer by **March 28, 2025**. Should the Contractor fail to complete and deliver the work before the above contract completion date, the Contractor shall be liable to pay the Village of Oak Park liquidated damages according to Section 108.09 of the Illinois Department of Transportation Standard Specifications for Road and Bridge Construction Adopted January 1, 2022. Extensions of contract time shall be according to Section 108.08 of the Illinois Department of Transportation Standard Specifications for Road and Bridge Construction Adopted January 1, 2022.

IV
PROPOSAL FORM

The undersigned proposes to perform the work as specified in Section III, "Detailed Specifications for the Sewer Cleaning and Inspection," of this call for proposals.

Unit Prices shall be filled out for all items

ITEM NO.	PAY ITEM	QUANTITY	UNIT	UNIT PRICE -\$-	TOTAL PRICE -\$-
1	TRAFFIC CONTROL AND PROTECTION	1	L SUM		
2	UPPER SEWER CHAMBER CLEANING AND INSPECTION	200	HOUR		
3	PERFORATED DRAIN PIPE INSPECTION	397	FEET		
4	FLANGE REMOVAL	50	HOUR		
5	SEWER SIPHON CLEANING	200	HOUR		
6	DEBRIS DISPOSAL	200	TON		
7	SEWER TELEVISION INSPECTION, 14"	390	FEET		
8	SEWER TELEVISION INSPECTION, 30"	390	FEET		
9	SEWER TELEVISION INSPECTION, 54"	390	FEET		
10	STOP PLANK REPLACEMENT CONTINGENCY ALLOWANCE	1	L SUM	\$15,000.00	\$15,000.00

Total =

Proposal Signature: _____

State of _____)

County of _____)

(Type/Print Name of Signee)

being first duly sworn on oath deposes and says that the Vendor on the above Proposal is organized as indicated below and that all statements herein made on behalf of such Vendor and that their deponent is authorized to make them, and also deposes and says that deponent has examined and carefully prepared their proposal from the Contract.

IV
PROPOSAL FORM (cont.)

Specifications and has checked the same in detail before submitting their Proposal; that the statements contained herein are true and correct.

Signature of Vendor authorizes the Village of Oak Park to verify references of business and credit at its option.

Signature of Vendor shall also be acknowledged before a Notary Public or other person authorized by law to execute such acknowledgments.

Dated: _____

Organization Name

(Seal - If Corporation)

By: _____
Authorized Signature

Address

Telephone

Subscribed and sworn to before me this _____ day of _____, 20____.

Notary Public

In the State of _____.

My Commission Expires: _____.

IV
PROPOSAL FORM (cont.)

(Complete Applicable Paragraph Below)

(a) Corporation

The Vendor is a corporation, which operates under the legal name of _____ and is organized and existing under the laws of the State of _____.

The full names of its Officers are:

President _____

Secretary _____

Treasurer _____

The corporation does have a corporate seal. (In the event that this proposal is executed by a person other than the President, attach hereto a certified copy of that section of Corporate By-Laws or other authorization by the Corporation that permits the person to execute the offer for the corporation.)

(b) Partnership

Name, Signature and Addresses of all Partners

The partnership does business under the legal name of

_____, which name is registered with the office of _____ in the county of _____

IV
PROPOSAL FORM (cont.)

(c) Sole Proprietor

The Vendor is a Sole Proprietor whose full name is

_____ . If the Vendor is operating under

a trade name, said trade name is _____,

which name is registered with the office of _____

in the county of _____.

Signed: _____

Sole Proprietor

V
CONTRACTOR'S CERTIFICATION
(PROPOSAL)

_____, as part of its proposal on a contract for
(name of contractor)

_____ to the Village of Oak Park, hereby
(general description of item(s) proposal on)

certifies that said contractor is not barred from proposing on the aforementioned contract as a result of a violation to either Section 33E-3 or 33E-4 of Article 33E of Chapter 38 of the Illinois Revised Statutes or Section 2-6-12 of the Oak Park Village Code relating to "Proposing Requirements".

By: _____
(Authorized Agent of Contractor)

Subscribed and sworn to

before me this _____ day of

_____, 20__.

Notary Public

V

CONTRACTOR'S CERTIFICATION

_____, as part of its proposal on a contract for
(name of contractor)

_____ to the Village of Oak Park, hereby
(general description of item(s) proposal on)

certifies that said contractor is in compliance with House Bill 3337 which creates a Drug Free Workplace Act for Illinois with an effective date of January 1, 1992.

By: _____
(Authorized Agent of Contractor)

Subscribed and sworn to

before me this _____ day of

_____, 20__.

Notary Public

VI

TAX COMPLIANCE AFFIDAVIT

_____, being first duly sworn, deposes and
says: that he/she is _____ of
(partner, officer, owner, etc.)

(contractor)

The individual or entity making the foregoing proposal or proposal certifies that he/she is not barred from contracting with the Village of Oak Park because of any delinquency in the payment of any tax administered by the Department of Revenue unless the individual or entity is contesting, in accordance with the procedures established by the appropriate revenue act, liability for the tax or the amount of the tax. The individual or entity making the proposal or proposal understands that making a false statement regarding delinquency in taxes is a Class A Misdemeanor and, in addition, voids the contract and allows the municipality to recover all amounts paid to the individual or entity under the contract in civil action.

(Name of Vendor if the Vendor is an Individual)
(Name of Partner if the Vendor is a Partnership)
(Name of Officer if the Vendor is a Corporation)

The above statement must be subscribed and sworn to before a notary public.

Subscribed and sworn to this _____ day of _____, 20__.

Notary Public

VII

FAIR EMPLOYMENT PRACTICES

AFFIDAVIT OF COMPLIANCE

NOTE: This affidavit must be executed and submitted with the signed proposal form. No proposals can be accepted by the Board of Trustees of the Village of Oak Park unless said affidavit is submitted concurrently with the proposal.

_____, being first duly sworn, deposes and says that
(name of person making the Affidavit)

_____ of _____ and that he/she
(Title or Office) (Name of Company)

has the authority to make the following affidavit; that he/she has the knowledge of the Village of Oak Park Ordinance relating to Fair Employment Practices and knows and understands the contents thereof; that he/she certifies hereby that _____

(Name of Company)

is an "Equal Opportunity Employer" as defined by Section 2000 (E) of Chapter 21, Title 42 of the United States Code Annotated and Federal Executive Orders #11246 and #11375 which are incorporated herein by reference.

(Signature)

Subscribed and sworn to before

me this _____ day of

_____, 20__.

Notary Public

VIII
VILLAGE OF OAK PARK
E.E.O. REPORT

Please fill out this form completely. Failure to respond truthfully to any questions on this form, or failure to cooperate fully with further inquiry by the Village of Oak Park will result in disqualification of this proposal. An incomplete form will disqualify your proposal. For assistance in completing this form, contact Elaine Avgoustakis at 708-358-5726.

An EEO-1 Report may be submitted in lieu of their report

1. Vendor Name: _____

2. Check here if your firm is:

_____ MBE

_____ WBE

_____ Non-MBE/WBE

3. What is the size of the firm's current stable work force?

_____ Number of full-time employees

_____ Number of part-time employees

4. Similar information will be requested of all subcontractors working on this contract. Forms will be furnished to the low responsible vendor with the notice of contract award, and these forms must be completed and submitted to the Village before the execution of the contract by the Village.

AFFIDAVIT OF M/WBE STATUS

I am _____ of _____, and have authority to execute this affidavit on behalf of this firm. I _____ do
(Name of Affiant)

hereby certify that:

1. This firm is a (Check one Only)
 - Minority Business Enterprise (MBE) (A firm that is at least 51% owned, managed and controlled by a Minority.)
 - Women’s Business Enterprise (WBE) (A firm that is at least 51% owned, managed and controlled by a Woman.)
2. **COPIES OF ALL MBE, WBE OR DBE CERTIFICATIONS HAVE BEEN ATTACHED.**
3. The following information will be provided upon written request, through the Prime Contractor or, if no Prime, directly to the Village of Oak Park.
 - a) Actual work performed on any project and the payment thereof; and,
 - b) Any proposal changes, in the status of the firm, which would render this affidavit null and void.
 - c) Further verification of the indicated status

Signature: _____ Date: _____
Corporate Seal (where appropriate)

This instrument was acknowledged before me this _____ day of _____, By _____ as President (or other authorized officer) of _____
(Firm Name)

(Notary Public Signature)

Commission Expires: _____ Notary Seal

VIII (Continued)
VILLAGE OF OAK PARK
EEO REPORT

Vendor Name _____
 Total Employees _____

Job Categories	Total Employees	Total Males	Total Females	Males				Females				Total Minorities
				Black	Hispanic	American Indian & Alaskan Native	Asian & Pacific Islander	Black	Hispanic	American Indian & Alaskan Native	Asian & Pacific Islander	
Officials & Managers												
Professionals												
Technicians												
Sales Workers												
Office & Clerical												
Semi-Skilled												
Laborers												
Service Workers												
TOTAL												
Management Trainees												
Apprentices												

This completed and notarized report must accompany your bid. It should be attached to your Affidavit of Compliance. Failure to include it with your bid will be disqualify you from consideration.

An EEO-1 Report may be submitted in lieu of this report.

_____, being first duly sworn, deposes and says that he/she is the _____
 (Name of Person Making Affidavit) (Title or Officer)
 of _____ and that the above EEO Report information is true and accurate and is submitted with the intent that it
 be relied upon. Subscribed and sworn to before me this _____ day of _____, 20____.

 (Signature) (Date)

IX

NO PROPOSAL EXPLANATION

If your firm does not wish to propose on the attached specifications, please return this proposal along with any comments you may have that prevented your firm from submitting a proposal.

Thank you.

Comments:

F. A. I. ROUTE NO.	SEC.	EXPRESSWAYS	TOTAL SHEETS	SHEET NO.
STA.		TO STA.		
FED. ROAD DIST. NO. 7	ILLINOIS	FED. AID PROJECT		

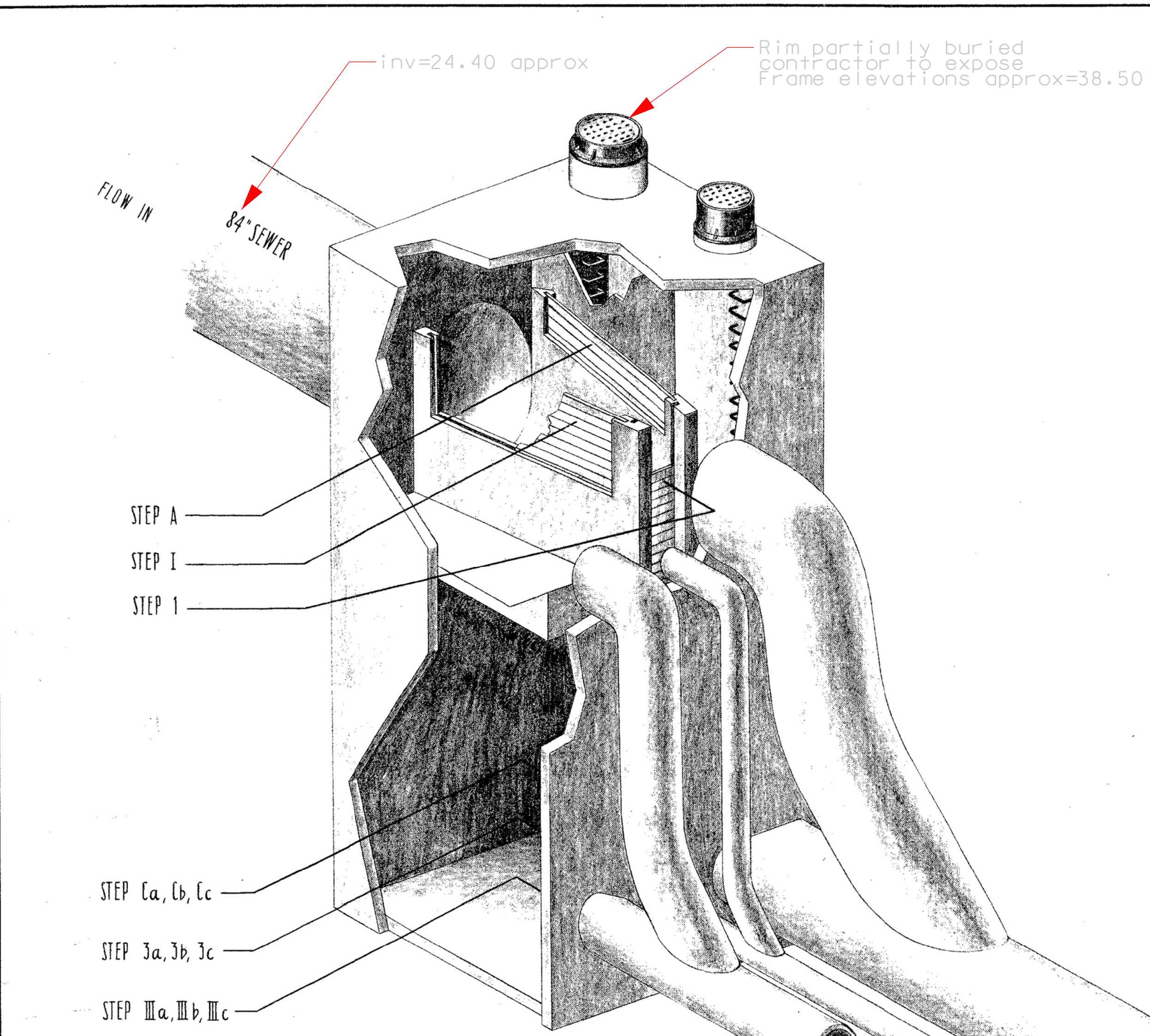

- ### 14" SEWER
- STEP 1 REMOVE APPROPRIATE STOP-PLANKS FROM RACK AND PLACE IN GROOVE TO DAM THE 14" OPENING IN NORTH CHAMBER.
 - STEP 2 REPEAT STEP 1 IN SOUTH CHAMBER. (RACK IN LOWER CHAMBER).
 - STEP 3a LOOSEN BOLT IN 21" DIA. BLIND FLANGE IN NORTH CHAMBER - BUT DO NOT REMOVE COMPLETELY.
 - 3b ALLOW WATER IN PIPE TO FLOW OUT FROM SIDE OF LOOSENED FLANGE.
 - 3c AFTER PIPE IS COMPLETELY DRAINED, REMOVE THE BLIND FLANGE USING BLOCK AND TACKLE HOOKED TO IRON BAR PROVIDED IN CEILING.
 - 3d REMOVE 21" DIA. BLIND FLANGE IN SOUTH CHAMBER AS IN "3c". THE PIPE IS NOW READY FOR INSPECTION AND CLEANING.
 - STEP 4 AFTER PIPE IS CLEANED, REPLACE THE BLIND FLANGES IN BOTH CHAMBERS. REMOVE AND RETURN THE STOP-PLANKS TO THE RACK, FIRST IN THE SOUTH CHAMBER THEN IN THE NORTH CHAMBER.

MAINTENANCE PROCEDURE

- ### 30" SEWER
- STEP I REMOVE APPROPRIATE STOP-PLANKS FROM RACK AND PLACE IN GROOVE TO DAM THE 30" OPENING IN NORTH CHAMBER.
 - STEP II REPEAT STEP I IN SOUTH CHAMBER. (RACK IN LOWER CHAMBER).
 - STEP IIIa LOOSEN BOLT IN WEST 32" DIA. BLIND FLANGE IN NORTH CHAMBER - BUT DO NOT REMOVE COMPLETELY.
 - IIIb ALLOW WATER IN PIPE TO FLOW OUT FROM SIDE OF LOOSENED FLANGE.
 - IIIc AFTER PIPE IS COMPLETELY DRAINED, REMOVE THE BLIND FLANGE USING BLOCK AND TACKLE HOOKED TO IRON BAR PROVIDED IN CEILING.
 - IIId REMOVE WEST 32" DIA. BLIND FLANGE IN NORTH CHAMBER AS IN "IIIc". THE PIPE IS NOW READY FOR INSPECTION AND CLEANING.
 - STEP IV AFTER PIPE IS CLEANED, REPLACE THE BLIND FLANGES IN BOTH CHAMBERS. REMOVE AND RETURN THE STOP-PLANKS TO THE RACK, FIRST IN THE SOUTH CHAMBER THEN IN THE NORTH CHAMBER.

- ### 54" SEWER
- STEP A REMOVE APPROPRIATE STOP-PLANKS FROM RACK AND PLACE IN GROOVE TO DAM THE 54" OPENING IN NORTH CHAMBER.
 - STEP B REPEAT STEP A IN SOUTH CHAMBER. (RACK IN LOWER CHAMBER).
 - STEP Ca LOOSEN BOLT IN EAST 32" DIA. BLIND FLANGE IN NORTH CHAMBER - BUT DO NOT REMOVE COMPLETELY.
 - Cb ALLOW WATER IN PIPE TO FLOW OUT FROM SIDE OF LOOSENED FLANGE.
 - Cc AFTER PIPE IS COMPLETELY DRAINED, REMOVE THE BLIND FLANGE USING BLOCK AND TACKLE HOOKED TO IRON BAR PROVIDED IN CEILING.
 - Cd REMOVE EAST 32" DIA. BLIND FLANGE IN NORTH CHAMBER AS IN "Cc". THE PIPE IS NOW READY FOR INSPECTION AND CLEANING.
 - STEP D AFTER PIPE IS CLEANED, REPLACE THE BLIND FLANGES IN BOTH CHAMBERS. REMOVE AND RETURN THE STOP-PLANKS TO THE RACK, FIRST IN THE SOUTH CHAMBER THEN IN THE NORTH CHAMBER.

MAINTENANCE PROCEDURE, AS OUTLINED ABOVE, SHALL BE FULLY COMPLETED ON EACH PIPE BEFORE PROCEEDING TO THE NEXT PIPE.

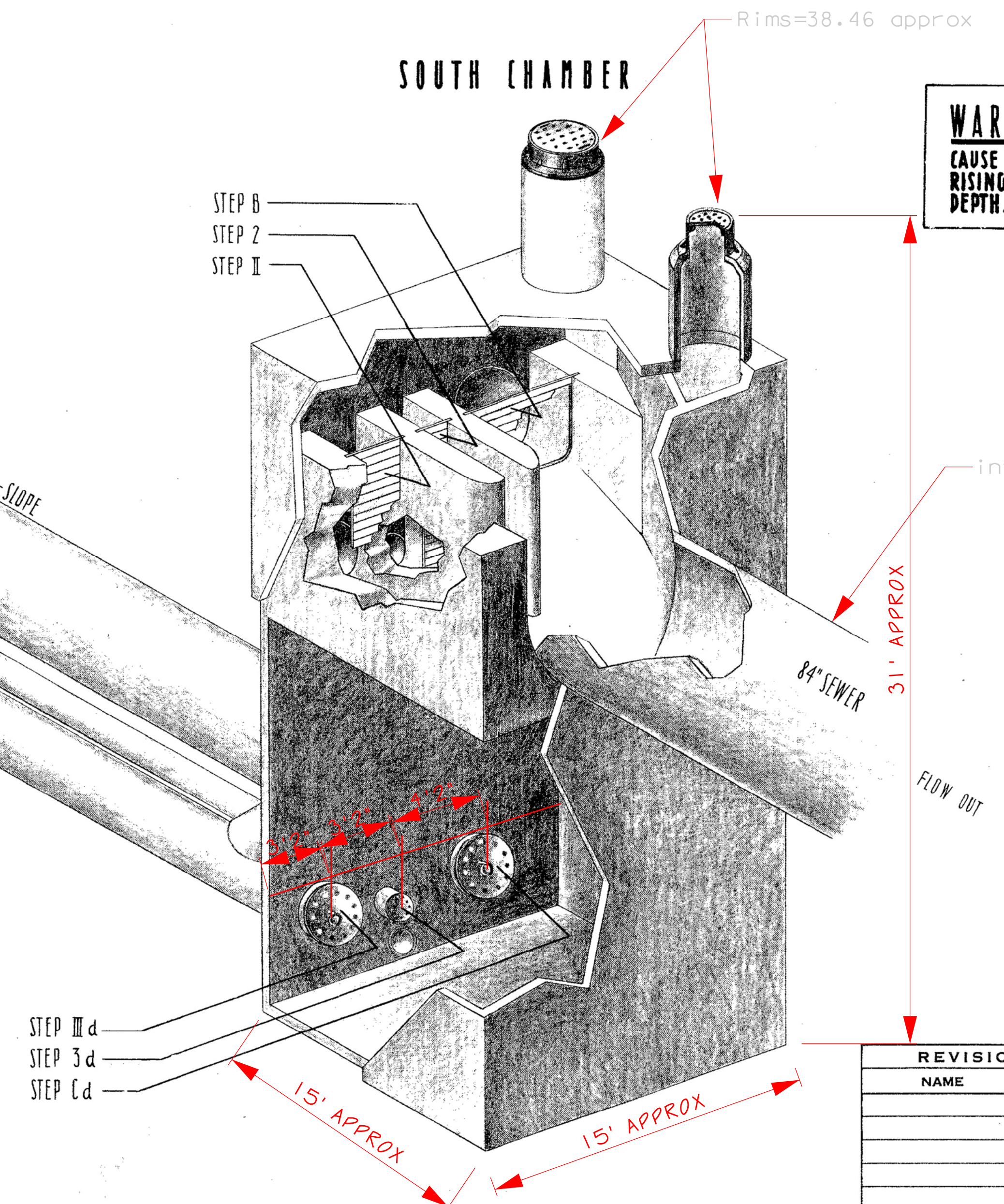

WARNING DURING STEP 3, III AND C, EXERCISE CAUTION BECAUSE OF THE POSSIBILITY OF THE WATER RISING IN THE CHAMBER TO AN EXCESSIVE DEPTH.

GENERAL INFORMATION			
FLANGE DIA.	DIA. OF BOLTS	LENGTH OF BOLTS	APPROX. FLANGE WEIGHT
21"	1"	4 1/4"	130 #
32"	1 1/4"	5 1/2"	300 #

APPROXIMATE VOLUME OF WATER IN 14" PIPE • 4,000 GALS.
 APPROXIMATE VOLUME OF WATER IN 30" PIPE • 15,000 GALS.
 APPROXIMATE VOLUME OF WATER IN 54" PIPE • 48,000 GALS.

REVISIONS	
NAME	DATE

ILLINOIS DIVISION OF HIGHWAYS
 CONGRESS STREET EXPRESSWAY

RIDGELAND AVE. SEWER SIPHON

SCALE: HORIZ. VERT. DATE 4-26-61

DRAWN BY H.E.T.
 CHECKED BY

STATE OF ILLINOIS
 DEPARTMENT OF PUBLIC WORKS AND BUILDINGS
 DIVISION OF HIGHWAYS
 PLANS FOR PROPOSED
 FEDERAL AID HIGHWAY

FAI-90

ROUTE NO.	SEC.	COUNTY	TOTAL SHEETS	SHEET NO.
FAI 1	3132-217-T	COOK	13	1

INDEX OF SHEETS

- SHEET NO. 1. TITLE SHEET
- SUMMARY OF QUANTITIES
 - GENERAL PLAN & PROFILE
 - STAGES OF CONSTRUCTION
 - SOIL BORING - LOCATION DETAILS
 - INLET CHAMBER DETAILS
 - INLET CHAMBER REINFORCING
 - OUTLET CHAMBER DETAILS
 - OUTLET CHAMBER REINFORCING
 - BAR SCHEDULE
 - STANDARD 1790F 1516S
 - STANDARD 1527S 1526R 2112
 - STANDARD 1771S, 1777T, 2114

FAI-90

0-34

F.A.I. ROUTE 1 SEC. 3132-217-T
 CONGRESS ST. EXPRESSWAY
 RIDGELAND AVENUE SEWER SIPHON
 PROJECT I-01-4(33)
 COOK COUNTY

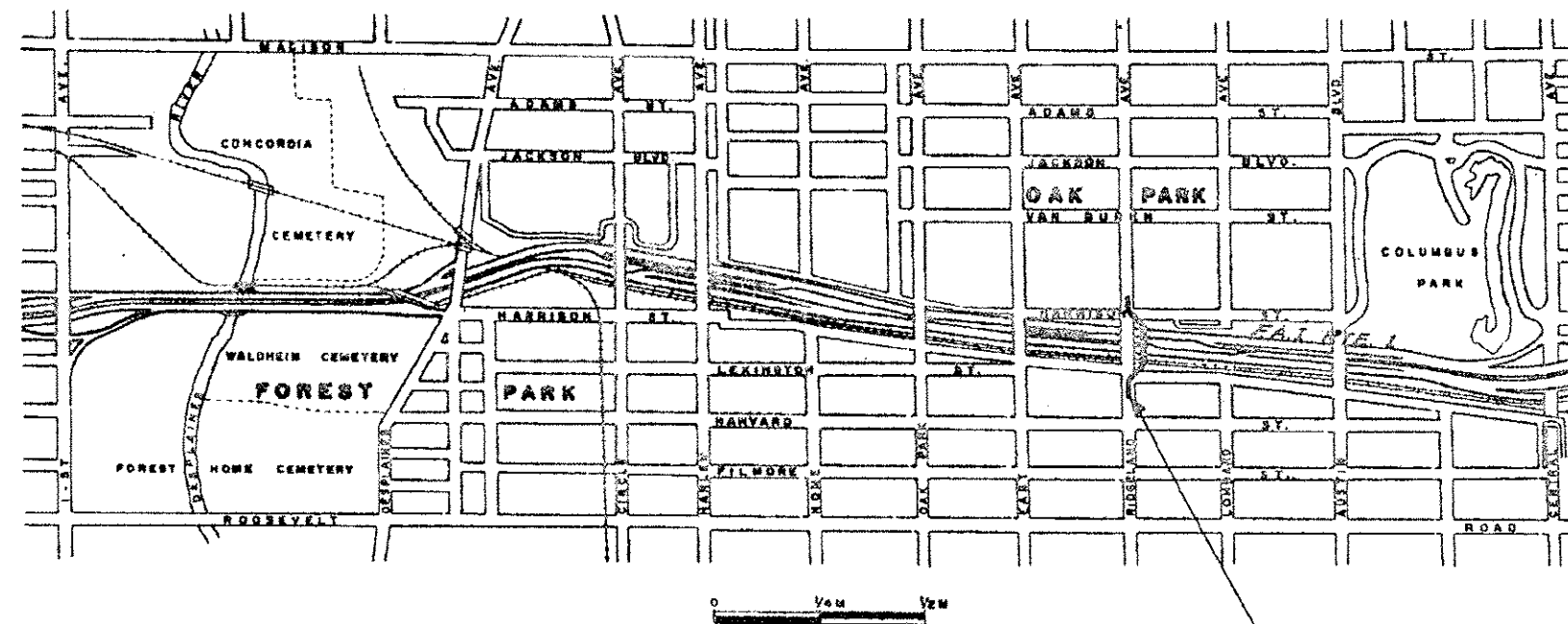

DESCRIPTION OF IMPROVEMENT

THIS IMPROVEMENT CONSISTS OF THE CONSTRUCTION OF A THREE PIPE SEWER SIPHON INCLUDING CONCRETE JUNCTION CHAMBERS ACROSS THE CONGRESS STREET EXPRESSWAY AT STATION 137+80.89. ALSO INCLUDED IS THE CONSTRUCTION OF A NEW 12" CAST IRON WATER MAIN.

STATE OF ILLINOIS
 DEPARTMENT OF PUBLIC WORKS & BUILDINGS
 SUBMITTED 12-20-56
 EXAMINED 12-26-56
 LABELED 12-26-56
 APPROVED 12-26-56
 APPROVED 12-26-56

DEPARTMENT OF COMMERCE
 BUREAU OF PUBLIC ROADS
 APPROVED
 DISTRICT ENGINEER DATE

PREPARED BY: *[Signature]* 12-17-56
 EXPRESSWAY DESIGN ENGINEER
 EXAMINED BY: *[Signature]* 12-22-56
 DISTRICT CONSTRUCTION ENGINEER
 EXAMINED BY: *[Signature]* 12-20-56
 EXPRESSWAY ENGINEER
 ENTIRE SECTION INSPECTED AND APPROVED AS TO POLICY BY: *[Signature]*
 DISTRICT ENGINEER

COOK COUNTY SECTION 3132-217-T ROUTE FAI. 1

WPH 1-2-57
 JES 1-3-57

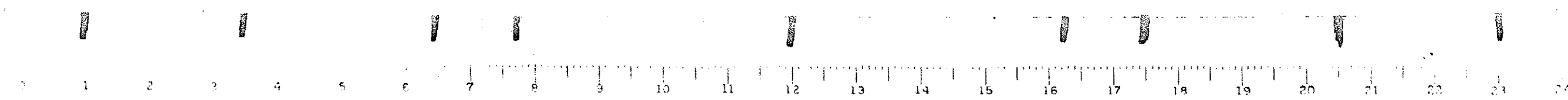

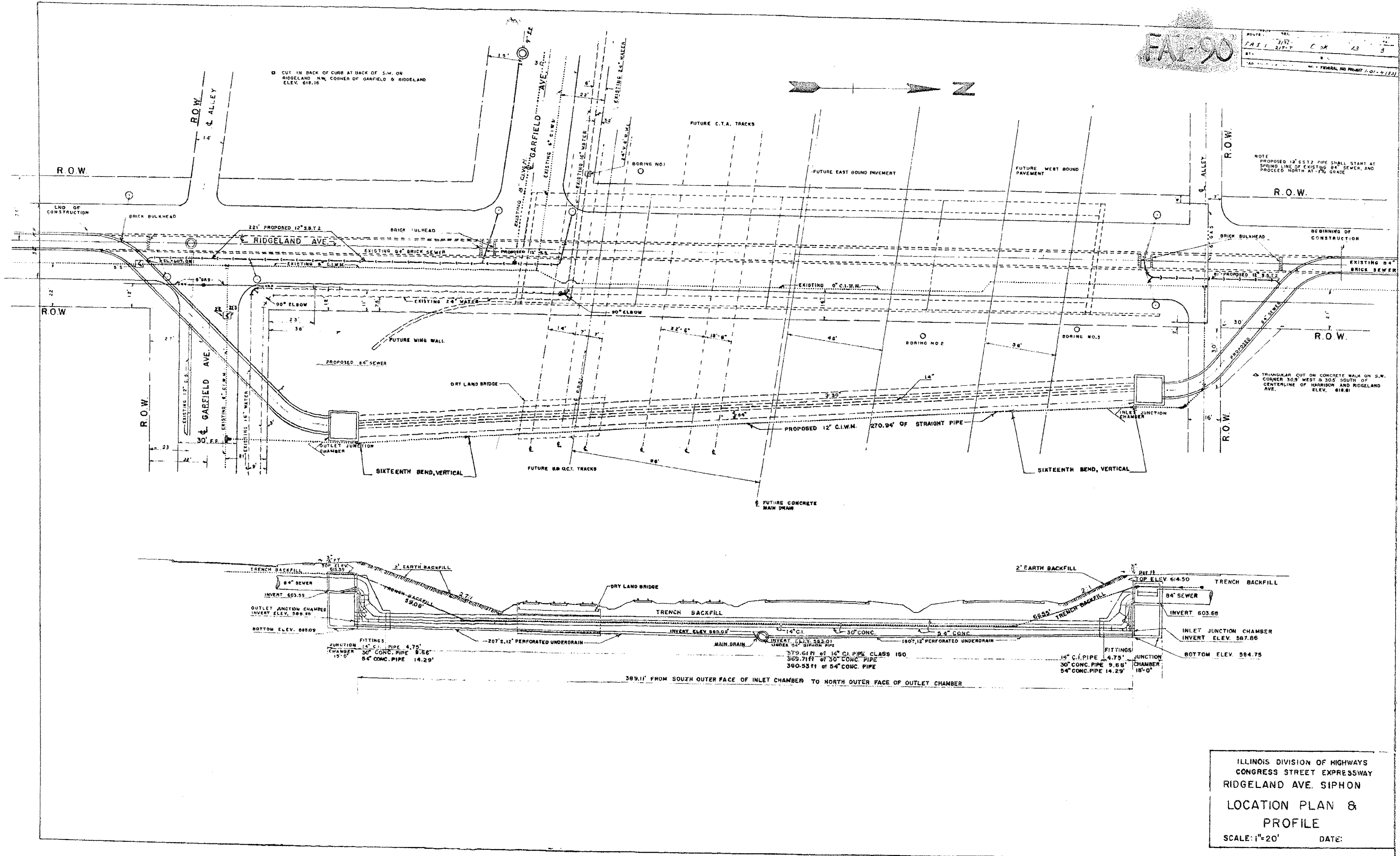

ROUTE 112
 DATE 10-1-57
 SHEET 13 OF 13
 FEDERAL PROJECT 1-01-1-113

NOTE
 PROPOSED 12" S172 PIPE SHALL START AT
 SPRING LINE OF EXISTING 84" SEWER, AND
 PROCEED NORTH AT 1% GRADE

TRIANGULAR CUT ON CONCRETE WALK ON S.W.
 CORNER 304 WEST & 305 SOUTH OF
 CENTRAL LINE OF HARRISON AND RIDGELAND
 AVE. ELEV. 618.81

ILLINOIS DIVISION OF HIGHWAYS
 CONGRESS STREET EXPRESSWAY
 RIDGELAND AVE. SIPHON
 LOCATION PLAN &
 PROFILE
 SCALE: 1"=20' DATE:

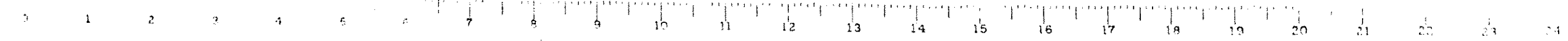

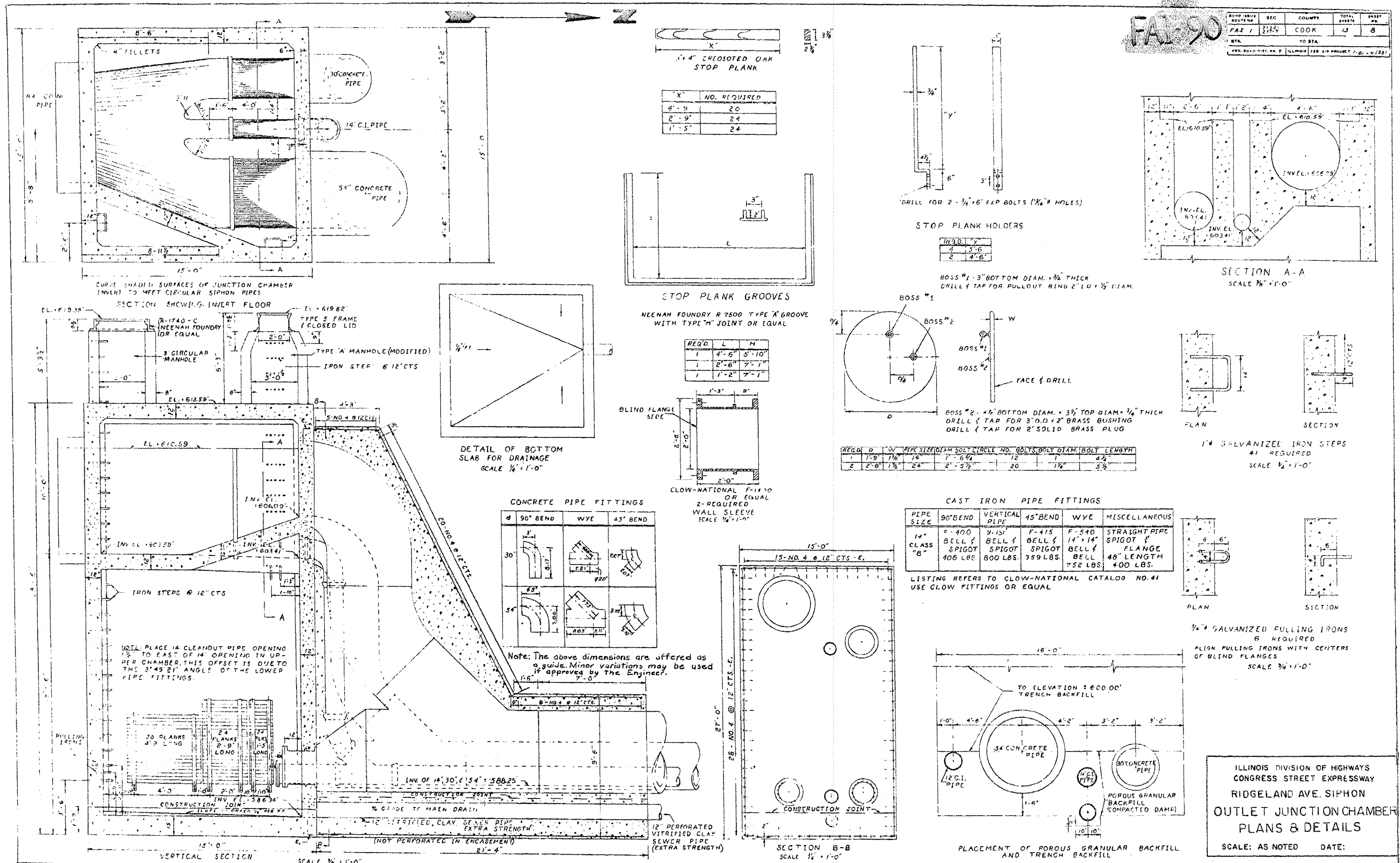

BLDG. NO.	SEC.	COUNTY	TOTAL SHEETS	SHEET NO.
FAZ 1	3122	COOK	43	8
BTA	TO BTA			
FED. ROAD DIST. NO. 7 ILLINOIS 228 210 PROJECT 1, 2, 3, 4, 5, 6, 7, 8, 9, 10, 11, 12, 13, 14, 15, 16, 17, 18, 19, 20, 21, 22, 23, 24				

X"	NO. REQUIRED
4'-9"	20
2'-9"	24
1'-5"	24

REQD.	L	H
1	4'-6"	5'-10"
1	2'-6"	7'-1"
1	1'-2"	7'-1"

REQD.	D	W	PIPE SIZE	DIAM.	SOLY. CIRCLE NO.	BOLTS	BOLY. DIAM.	BOLT LENGTH
1	7'-8"	7'-6"	7"	8 1/4"	12	1	1/2"	4 1/2"
2	2'-8"	7"	2 1/2"	2 1/2"	20	1/4"	3 1/2"	

PIPE SIZE	90° BEND	VERTICAL PIPE	45° BEND	WYE	MISCELLANEOUS
14" CLASS "B"	F-400 BELL & SPIGOT 406 LBS.	F-151 BELL & SPIGOT 800 LBS.	F-415 BELL & SPIGOT 359 LBS.	F-540 BELL & SPIGOT 752 LBS.	STRAIGHT PIPE SPIGOT & FLANGE 48" LENGTH 400 LBS.

LISTING REFERS TO CLOW-NATIONAL CATALOG NO. 41 USE CLOW FITTINGS OR EQUAL

ILLINOIS DIVISION OF HIGHWAYS
 CONGRESS STREET EXPRESSWAY
 RIDGE LAND AVE. SIPHON
 OUTLET JUNCTION CHAMBER
 PLANS & DETAILS
 SCALE: AS NOTED DATE:



